



www.alltekmarine.com

CAMINO-101

[ **Class B AIS** ]

İ q Y f Manual





**COPYRIGHT**

The entire contents of this instruction manual, including any future updates, revisions, and modifications, shall remain the property of AMEC at all times. Unauthorized copies or reproduction of this manual, either in part or whole, in any form of print and electronic media, is prohibited. The contents herein can only be used for the intended purpose of this manual.

**DISCLAIMER**

AMEC is devoted to publish and maintain this product manual. As we continue to improve our products, information in this document is subject to change without notice. AMEC does not make any representations or warranties (implied or otherwise) regarding the accuracy and completeness of this document and shall in no event be liable for any loss of profit or any commercial damage, including but not limited to special, incidental, consequential, or other damage.

**Contact us at:**

**Technical Support:**

(Your Local Dealer/Agent Warranty Stamp)
--

**Sales & Marketing:**

**ALLTEK MARINE ELECTRONICS CO., LTD**

7F, No. 605, Ruei-Guang Rd., Neihu, Taipei, Taiwan 114

TEL: +886 2 2627 1599

FAX: +886 2 2627 1600

[www.alltekmarine.com](http://www.alltekmarine.com)

## WARNING!

FOR USERS IN THE UNITED STATES OF AMERICA ONLY

**WARNING: It is a violation of the rules of the Federal Communications Commission to input an MMSI that has not been properly assigned to the end user, or to otherwise input any inaccurate data in this device.**

The entry of static data into this device shall be performed by the vendor of the device or by an appropriately qualified person in the business of installing marine communications equipment on board vessels.

Instructions on how to accurately enter and confirm static data in the device can be found in Section 3.3 of this user manual.

The equipment said in this manual must only be used to which it was designed. Improper operation or installation may cause damage to the equipment or injury to personnel. AMEC will not incur any liability of equipment damage or personal injury due to improper use or installation of the equipment. It is strongly recommended to read this manual and the following safety instructions before proceeding to installation or operation.

## SAFETY INSTRUCTIONS

### WARNING



**ELECTRICAL SHOCK HAZARD.**

Do not open the case of the equipment. Only qualified personnel could work on the interior of the equipment.

**TURN OFF THE POWER IMMEDIATELY IF WATER LEAKS INTO THE EQUIPMENT OR OBJECT DROPS INTO THE EQUIPMENT.**

Continue operating the equipment could cause electrical shock or fire. Contact your nearest distributor for service.

**DO NOT DISASSEMBLE OR MODIFY THE EQUIPMENT.**

Improper disassemble or modification could cause electrical shocks, fire, or personal injury.

**AVOID OPERATING THE EQUIPMENT WITH WET HANDS.**

Electrical shocks could be resulted if operating with wet hands.

### WARNING

**TURN OFF THE POWER IMMEDIATELY IF THE EQUIPMENT IS EMMITTING SMOKE OR FIRE.**

Continue operating the equipment could cause electrical shock or fire. Contact your nearest distributor for service.

**EVENTHOUGH THE EQUIPMENT IS WATERPROOF, PLEASE AVOID DIRECT CONTACT WITH RAIN OR SPLASHING WATER.**

Electrical shock or fire could be resulted if water leaks into the equipment.

**DO NOT PLACE ANY LIQUID-FILLED CONTAINER ON TOP OF THE EQUIPMENT.**

Electrical shocks could be resulted if the device is contaminated with liquid.



## **FOREWORD**

Congratulations on the purchase of your new CAMINO-101 Automatic Identification System. We wish you a safe and enjoyable voyage on the surrounding sea, and have an enjoyable voyage.

Camino-101 AIS is strictly tested to meet the rigorous demands of the marine environment. Unless improper use, installation, or maintenance, the equipment should function properly at its optimum.

**We thank you for choosing our product and we wish you bon voyage!**



## Table of Contents

---

- I. COPYRIGHT & DISCLAIMER
- II. WARNING & SAFETY INSTRUCTION
- III. FORWARD

	Page
<b>1 INTRODUCTION .....</b>	<b>1</b>
1.1 CAMINO-101 Overview .....	1
1.2 Type of AIS .....	2
1.3 AIS Message Type .....	2
1.4 AIS Report Rate .....	3
1.5 About this Manual .....	3
1.6 Important Notice .....	3
<b>2 INSTALLATION .....</b>	<b>4</b>
2.1 General .....	4
2.1.1 Safety Instructions .....	4
2.1.2 Unpacking and Handling the Unit .....	5
2.1.3 Items in the Package .....	5
2.2 Installation Procedure .....	6
2.2.1 Installation Precautions .....	6
2.2.2 Step by Step Installation Instructions .....	7
2.2.3 Connector Pin Definition and Cable Wiring .....	11
2.2.4 VHF Antenna Installation .....	15
2.2.5 GPS Antenna Installation .....	16
2.2.6 Antenna Cabling .....	16
2.2.7 CAMINO-101 External Connections .....	17
2.2.8 AMEC AIS Configuration Software Installation .....	18
2.3 AMEC AIS Viewer Software Installation .....	22
2.4 Bluetooth Pairing (Optional Feature) (CAMINO-101W only) .....	25
<b>3 GET STARTED .....</b>	<b>26</b>
3.1 Turning Power ON / OFF .....	26
3.2 Front Panel LED Indicators .....	27
3.2.1 Built-in Integrity Test (BIIT) .....	28
3.3 CAMINO-101 Configuration Settings .....	29



3.3.1 Configuration Settings.....	29
3.3.2 Diagnosis Functions .....	33
<b>4 AMEC AIS VIEWER DESCRIPTION .....</b>	<b>36</b>
4.1 RS-232 Serial Port Selection .....	36
4.2 Running AMEC AIS Viewer .....	37
4.3 Display Indications.....	39
4.3.1 Area 1: Screen View .....	40
4.3.2 Area 2: Main Menu.....	44
( " ' " ' ' 5 f Y U ' ' . ' A m' J Y g g Y`Đ.g.Đ.d.c.g.]..h.]..c.b.Đ.].b.Z.c 55a U h	
4.3.4 Area 4: Ship List .....	56
4.3.5 Area 5: Ship Details Information .....	57
<b>5 APPENDIX .....</b>	<b>61</b>
5.1 Product Specifications.....	61
5.2 Dimensions .....	65
5.3 Ordering Information.....	66
5.4 Accessories .....	66
5.5 Trouble Shooting .....	67
5.5.1 Diagnosis by LED Indicators.....	67
5.5.2 Problem Analysis .....	68
<b>6 AMEC WORLD WIDE WARRANTY .....</b>	<b>70</b>
<b>7 FEDERAL COMMUNICATION COMMISSION INTERFERENCE STATEMENT</b> <b>.....</b>	<b>72</b>
<b>8 DECLARATION OF CONFORMITY .....</b>	<b>73</b>
<b>9 INDUSTRY CANADA NOTICE TO USERS .....</b>	<b>73</b>
<b>10 ABBREVIATIONS .....</b>	<b>73</b>

# 1 INTRODUCTION

## 1.1 CAMINO-101 Overview

The CAMINO-101 is a Class B AIS transponder using carrier-sense TDMA (CSTDMA) technology. It is designed to be inter-operable and compatible with Class A or other Class B ship-borne AIS stations or any other AIS stations operating on the AIS VHF data link.



CAMINO-101 AIS uses marine VHF channels with frequency set universally from 156.025 MHz to 162.025 MHz. Having CAMINO-101 AIS on board, not only can you monitor the status of the vessels in the surrounding area, but also receive the dynamic information (position, speed, SOG, and etc.), static information (ship name, MMSI, call sign, and etc.), and voyage related information (cargo type, destination, and etc.) from any vessels equipped with AIS. An external computer installed with AMEC AIS Viewer software or an AIS-ready plotter device is required in order to view the AIS information above mentioned.

CAMINO-101 AIS is one of the cutting-edge navigational aid equipments allowing real-time information exchanges within the AIS network. It is also capable of integrating with other maritime navigation applications.

CAMINO-101 is designed with 2 RF receivers and 1 RF transmitter. One of the RF receivers is time-shared between AIS and DSC. On the front panel, CAMINO-101 is equipped with 3 LED indicators. At rear panel, there are 1 VHF antenna connector, 1 GPS antenna connector, 1 optional Bluetooth connector and antenna (CAMINO-101W only), 1 NMEA interface connector, 1 RS232 interface connector (CAMINO-101A/W supports Tx-Off Switch Box via this connector), 1 power connector, and 1 power switch.

**NOTE:** The CAMINO-101 is an equipment to be used in protected environmental conditions. It is not intended to expose to rain or spray longer than a minute.

## 1.2 Type of AIS

There are mainly two types of AIS transponder: Class A and Class B. The intended nature of these AIS systems in navigations is different as illustrated in the following table. CAMINO-101 is a Class B AIS transponder.

**Table 1-2 Type of AIS**

<b>Class A AIS</b>	Transmits and receives AIS signal in SOTDMA protocols. Intended for vessels meeting the IMO AIS carriage requirements. It is mandatory for all commercial vessels that exceed 300 tons to be equipped with Class A AIS.
<b>Class B AIS</b>	Transmits and receives AIS signals in CSTDMA protocols. Not necessarily in accord with IMO AIS carriage requirements. It is not mandatory for vessels to be equipped with Class B AIS. Suitable for recreational vessels or fishing boats, in enhancing its safety at sea.

## 1.3 AIS Message Type

The CAMINO-101 transmits following message types.

**Table 1-3 CAMINO-101 AIS message type**

<b>Type of Message</b>	<b>Data Details</b>
<b>Static Data</b>	T æ  ã c ã { ^ Á T [ à ã   ^ Á Ù ^   ç ã & ^ Á Q á ^ } c ã c Call sign and name Type of ship Length and beam GPS Antenna location
<b>Dynamic Data</b>	Position of the vessel Ô [ ~   • ^ Á U ç ^   Á Õ   [ ~ } á Á Ç @ ^   ^ ã } æ ~ c ^   Speed Over Ground (hereinafter cæ    ^ á Á % ù U Õ + D Heading
<b>Dynamic Reports</b>	Speed of the ship Status of the ship
<b>SRM</b>	Alarm Safety





### 1.4 AIS Report Rate

The CAMINO-101 supports following report rates in accordance to ITU-R M.1371 and IEC 62287-1.

Table 1-4 CAMINO-101 AIS report rate

Platforms Condition	Nominal Reporting Interval
Class B Ship-borne mobile equipment not moving faster than 2 knots	3 Minutes
Class B Ship-borne mobile equipment moving faster than 2 knots	30 Seconds
Report rate by command of VTS	5 Seconds highest

### 1.5 About this Manual

The manual contains installation instructions and operating information for CAMINO-101. While most of the installation can be performed by the owner or the crew, a final commissioning can be done by your local agent/dealer when needed or required. AMEC and the local agent/dealer will not bear any responsibilities over any damages resulted in improper installation by unauthorized agent/dealer.

### 1.6 Important Notice

The intended use of the AMEC CAMINO-101 AIS is to enhance the safety of vessels at sea. However, a few points must be noted as below,

- › Any AIS cannot guarantee monitoring and receiving signals from all vessels in the surroundings unless those vessels are equipped with AIS devices.
- › It is important to note that the AIS is designed for the purpose of anti-collision and serves as a compliment to navigation. It is not the absolute navigational equipment and does not replace any navigational system installed on board.
- › Although AIS operates automatically by itself, the owner or the crew on the vessel should still maintain a proper lookout for the surroundings. While AIS is capable of setting alarms for vessels equipped with AIS, the vessel owner or the crew should be aware of the fact that there are vessels not equipped with AIS, and this function will not apply with these vessels.
- › Incorrect data and information entered into the AIS is considered as erroneous information.



Erroneous information or improper configuration will cause risk to both own vessel and surrounding vessels when these information are transmitted. Users must be aware of this risk and ensure that all information entered into the system is correct and up-to-date.

## 2 INSTALLATION

### 2.1 General

#### 2.1.1 Safety Instructions

Before proceeding with installation, take note of the following safety instructions and read through this installation manual carefully.

SAFETY INSTRUCTIONS	
<div style="background-color: black; color: white; text-align: center; padding: 2px;"><b>WARNING</b></div> <div style="padding: 5px;">  <p><b>ELECTRICAL SHOCK HAZARD</b> Do not open the case of the equipment. Only qualified personnel could work on the interior of the equipment.</p> </div> <hr/> <div style="padding: 5px;"> <p><b>TURN OFF THE POWER BEFORE PROCEEDING WITH INSTALLATION.</b> Proceeding with installation with the power on could cause electrical shock or fire.</p> </div> <hr/> <div style="padding: 5px;"> <p><b>AVOID INSTALLING THE EQUIPMENT WHERE THERE IS DIRECT CONTACT WITH RAIN OR SPLASHING WATER.</b> Electrical shock or fire could be resulted if water leaks into the equipment.</p> </div> <hr/> <div style="padding: 5px;"> <p><b>MAKE SURE THE POWER SOURCE AND THE POWER INPUT OF THE EQUIPMENT ARE COMPATIBLE.</b> Damage to the equipment and fire could be resulted if the power <b>sources are</b> not correct. Please check the correct power input on the adaptor.</p> </div>	<div style="padding: 5px;"> <p><b>FOLLOW THIS INSTRUCTION MANUAL TO PROCEED WITH THE INSTALLATION.</b> AMEC and your local agent/dealer will not bear any responsibility of equipment damage or personnel injury due to improper installation.</p> </div> <hr/> <div style="text-align: center; padding: 5px;">  <span style="font-weight: bold; font-size: 1.2em;">WARNING</span> </div> <hr/> <div style="padding: 5px;"> <p><u><b>Warning Label</b></u> A warning label (Figure 2-1-1) is attached underneath the equipment. Warranty of the equipment will be invalid if this label is detached or broken. AMEC and your local agent/dealer will not bear any responsibility of any damage to the equipment, or damage in related to the equipment, personnel injury, and etc. Reject the equipment if this label is detached or broken. Please contact your local agent/dealer if this label is missing.</p> </div>
<div style="border: 1px solid gray; border-radius: 15px; padding: 10px; display: flex; align-items: center; justify-content: center;"> <div style="text-align: center; margin-right: 10px;"> <p>Warning</p>  </div> <div style="border-left: 1px solid gray; padding-left: 10px;"> <p>Name: Warning Label No Warranty if this lab is detached or broken.</p> </div> </div>	

**Figure 2-1-1 Warning label**

## 2.1.2 Unpacking and Handling the Unit

① Move and handle with caution. Do not drop or bump.

② Visual inspection should be taken on the box to see if it is intact.

③ Unpack the product on a flat and level surface.

④ Unpack the box with the lid facing up.

⑤ Take extra caution if using sharp object to unpack.

⑥ After unpacked, check if all the accessories and units are included.

## 2.1.3 Items in the Package

The CAMINO-101 is typically delivered with standard package as shown in Table 2-1-3-1. It is also illustrated in Figure 2-1-3 (except Viewer CD and manual). Table 2-1-3-2 also shows optional accessories available from AMEC.

**Table 2-1-3 Standard equipment list**

No.	Description		Qty
1	CAMINO-101 Class B AIS main unit		1
2	Manual		1
3	Installation Kit	Power Cable, 1.5m, AWG 18	1
		NMEA 0183 interface cable, 1.5m	1
		RS-232 interface cable, 1.2m	1
		M6x20 Screws	4
4	Software CD: AMEC AIS Configuration & AMEC AIS Viewer		1

**NOTE:**

(1) AMEC would not be able to fully ensure overall product performance if longer cable length other than the above specified length is used.

(2) If an extension power cable is required, use large gauge cable to minimize voltage drops.

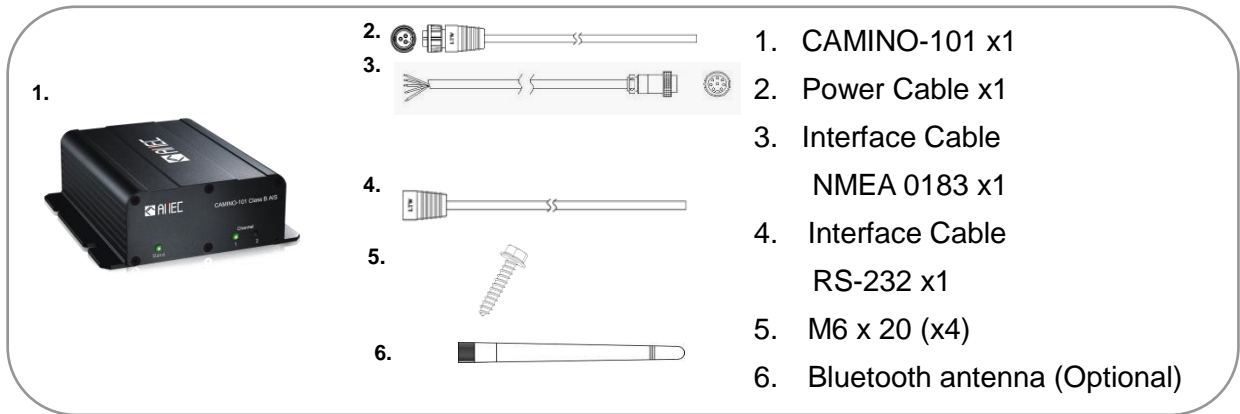

Figure 2-1-3 Package items

### 2.1.3.1 Optional Supply

Table 2-1-3-1 Optional equipment list

No.	Description	Remarks
1	VHF Antenna	--
2	GPS Antenna	10m cable included
3	VHF Antenna Cable	10m

**NOTE:** AMEC would not be able to fully ensure overall product performance if longer cable length other than the above specified length is used.

## 2.2 Installation Procedure

### 2.2.1 Installation Precautions

- ① Installation should proceed in a safe environment and does not have direct contact with rain or splashing water.
- ② If it is required to use a ladder to install the equipment, take extra caution and be careful of falling down.
- ③ Do not place or install the equipment beneath or near any container that filled with water or liquid.
- ④ Do not place or install the equipment where it is easily tripped, stepped on, or kicked at.
- ⑤ Do not place or install the equipment near any generator or engine.
- ⑥ When installation is completed, please remember to key in own g \ ] ~~MSI~~ data and related information through AMEC AIS Configuration software. Please refer to Section 3.3.

### 2.2.2 Step by Step Installation Instructions

AMEC CAMINO-101 can be installed and mounted on flat surface, or it can be mounted on wall as shown below.

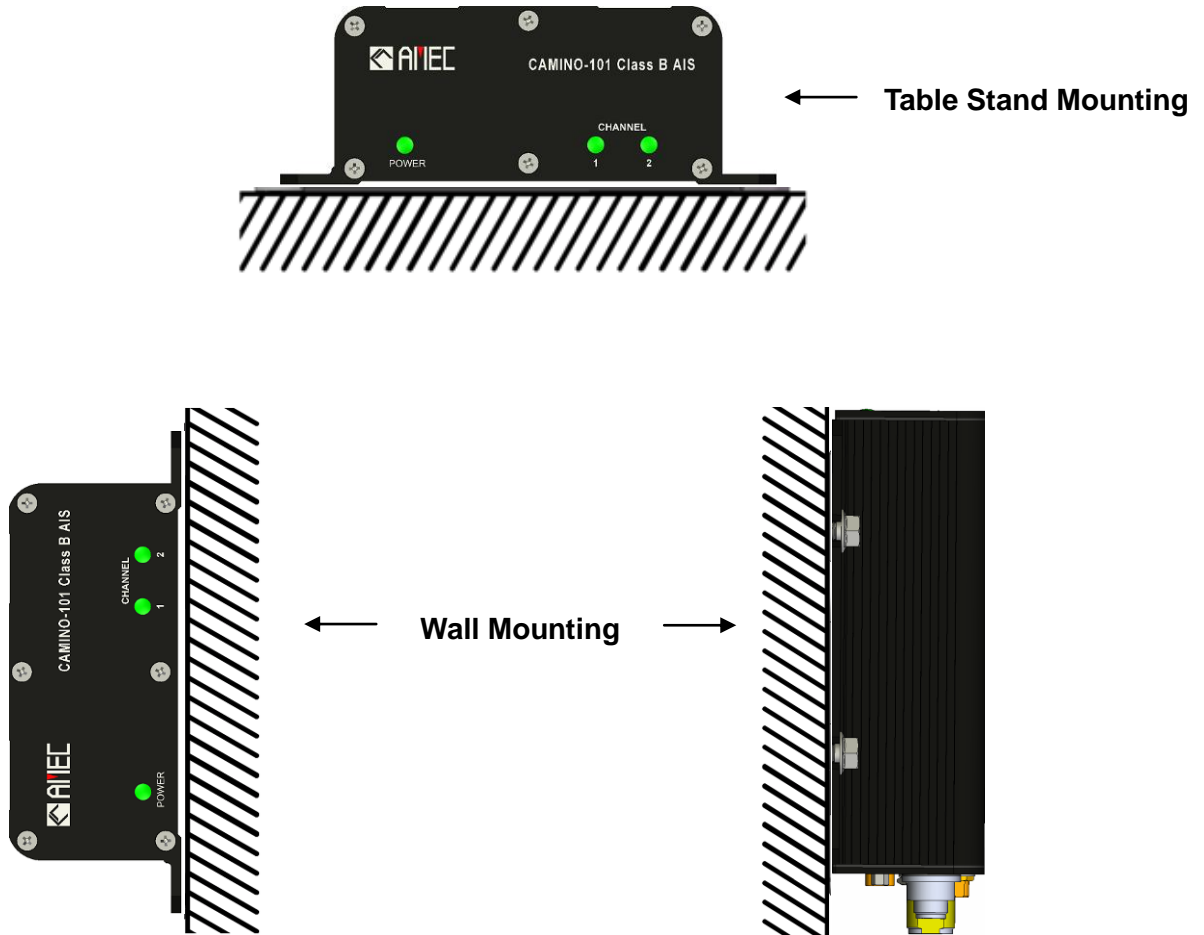
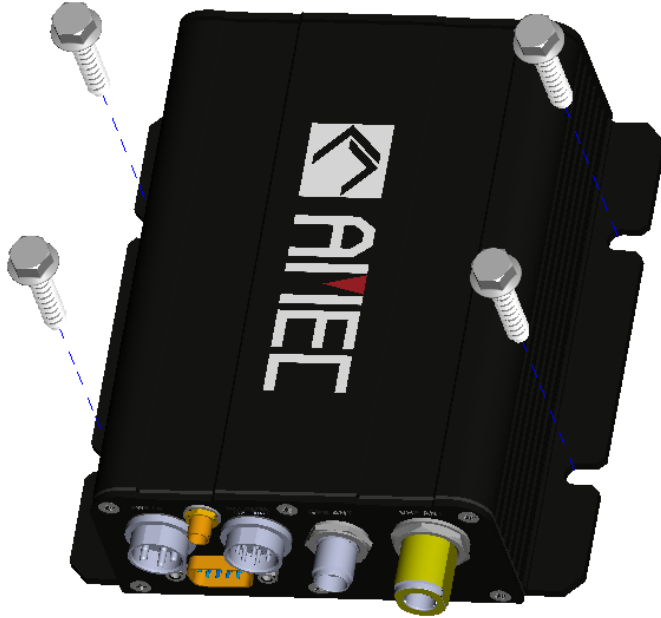

Figure 2-2-2-1 Installation overview

## I. Installation Instructions



### **Step 1:**

Place CAMINO-101 on the desired spot for installing.  
(Refer to figure 2-2-2-2)

### **Step 2:**

Use the supplied M6 × 20 screws from the accessories to mount.  
(Refer to figure 2-2-2-2)

Figure 2-2-2-2 Installation instruction

## II. Cabling Instructions

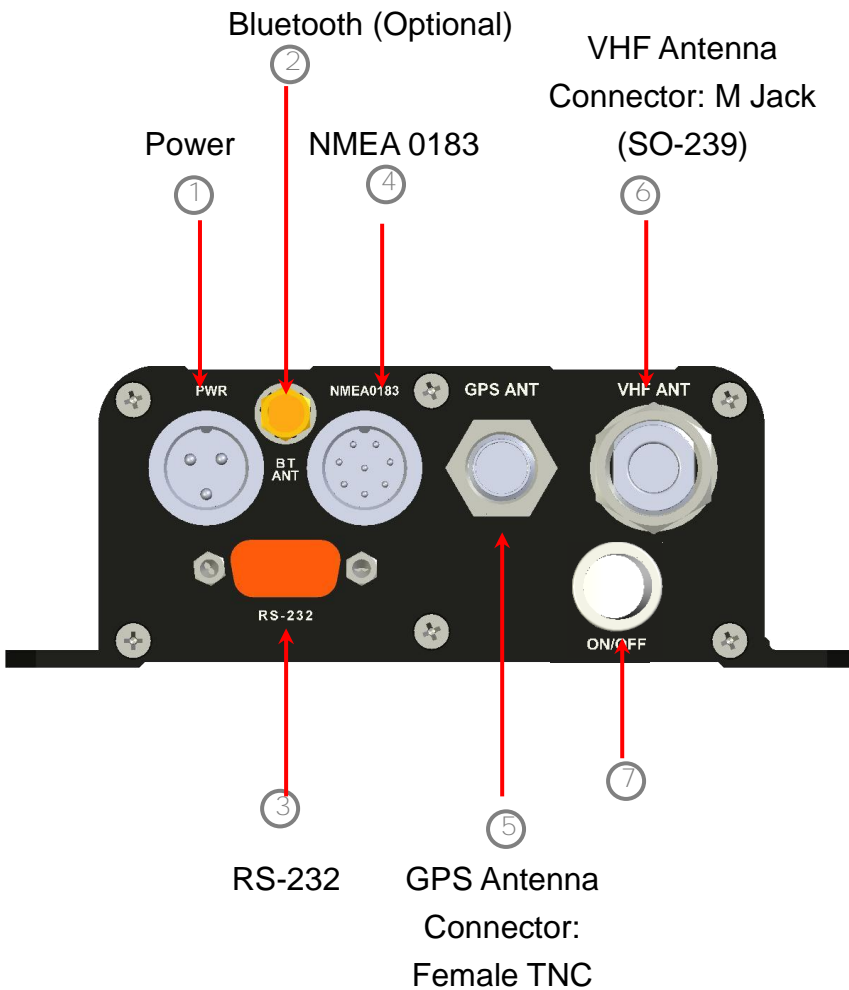

**Figure 2-2-2-3 Cabling instructions**

**Step 1:**  
Connect the GPS cable to the GPS ANT **5** \*.

**Step 2:**  
Connect the VHF cable to the VHF ANT **6**.

**Step 3:**  
Connect NMEA 0183 compatible system to the NMEA interface **4**.

**Step 4:**  
Connect either RS-232 or Bluetooth antenna to your computer if needed.  
**\* DO NOT CONNECT THE TWO INTERFACES SIMULTANEOUSLY.**

**Step 5:**  
Pairing Bluetooth to your computer if needed.  
(Please refer to 2-2-2-3).

**Step 6:**  
Connect the Power cable to the PWR **1**.

**Step 7:**  
Open the CAMINO-101 by

**\*NOTE: CAMINO-101 SUPPLIES ONLY 3.3V FOR GPS ANTENNA. WE RECOMMEND USING AMEC GPS ANTENNA (3.3V) WITH CAMINO-101. IF A 5V GPS ANTENNA IS CONNECTED TO CAMINO-101, IT MAY CAUSE DETERIORATION TO GPS RECEIVING PERFORMANCE.**

### III. Start-Up Setting

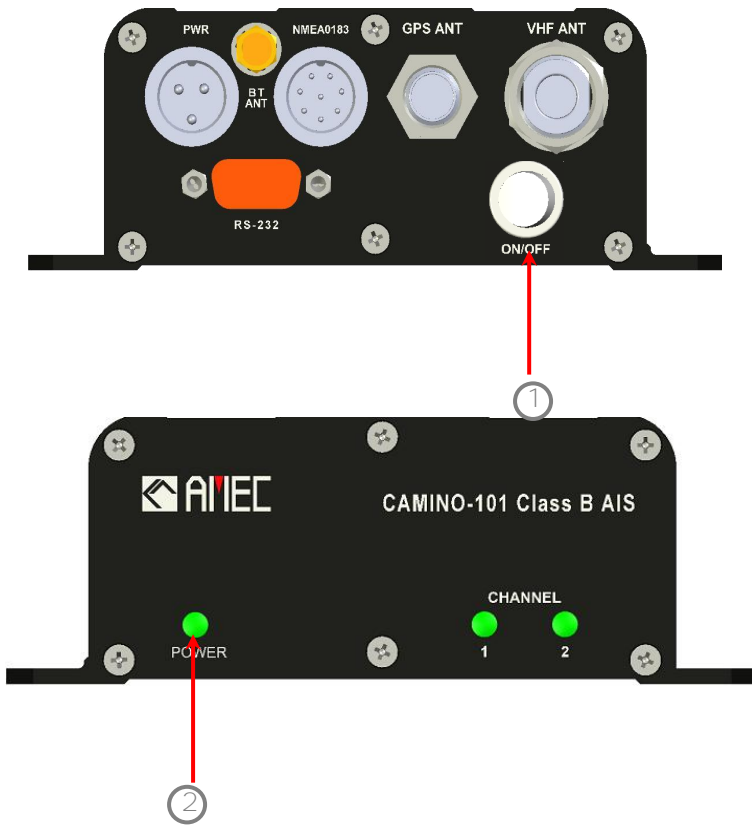

#### **Step 1:**

Connect the power cable to the power input and turn on CAMINO-101 by switching c [ Á %oU①+ È

#### **Step 2:**

Check if the POWER indicator ② is working properly.

Please refer to Section 3.1

Figure 2-2-3-4 Installation instruction

### IV. Remarks

① Set up the GPS and VHF antennas in appropriate spots.  
(Refer to Section 2.2)

② The required power voltage for CAMINO-101 is 12V / 24V DC. Use an adaptor if the supply voltage is not within the range.



**INCORRECT INPUT VOLTAGE WILL DAMAGE THE EQUIPMENT!**



## 2.2.3 Connector Pin Definition and Cable Wiring

### 2.2.3.1 Power Connector: Pin Definition and Cable Wiring

The power cable supplied has only a round connector at one end and there are two inner (red & black) wires. The wiring details are defined as follows:

**Table 2-2-3-1 Power connector pin definition**

Pin	Wire Color	Name	Function
1	-	-	-
2	Black	GND	Power Ground
3	Red	PWR	Positive ( ); the input should be 12V / 24V DC

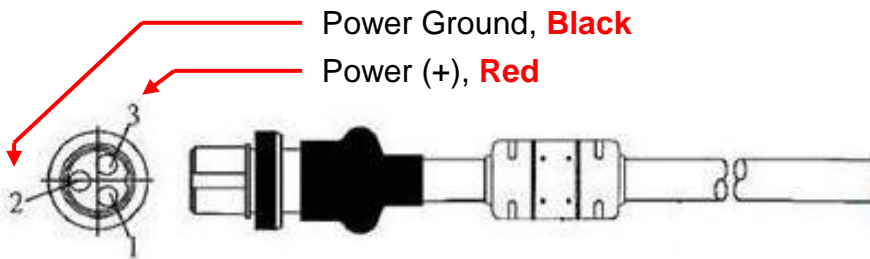

**Figure 2-2-3-1 Wiring definition in Power Cable**

### 2.2.3.2 NMEA 0183 Connector: Pin Definition and Cable Wiring

The NMEA 0183 cable supplied has only a round connector at one end and there are six inner wires. The wiring details of the NMEA cable are listed below.

**Table 2-2-3-2 NMEA 0183 pin definition**

Pin	Wire color	Name	Function
1	Brown	RXP	Positive( ); NMEA0183 Data input
2	Blue	RXN	Negative ( ); NMEA0183 Data input
3	White	TXP	Positive( ); NMEA0183 Data output
4	Green	TXN	Negative ( ); NMEA0183 Data output
5	/	/	/
6	Red	/	Reserved
7	Purple	/	Reserved
8	/	/	/

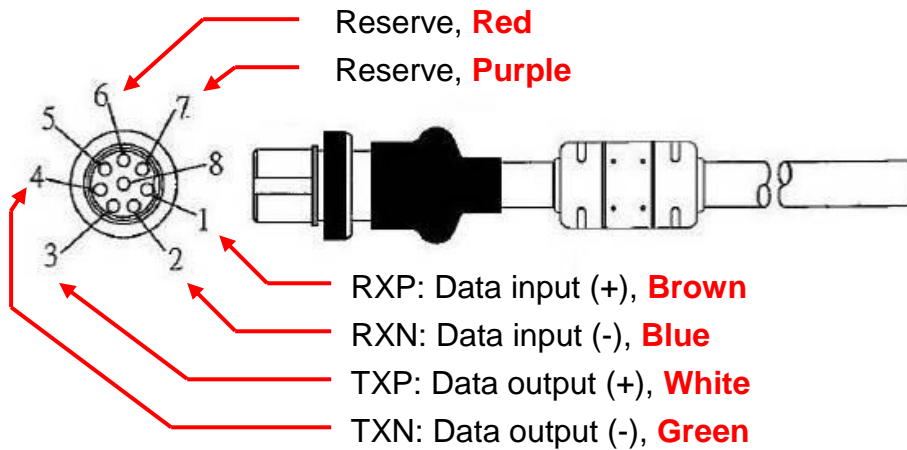

Figure 2-2-3-2 Wiring definition in NMEA 0183 cable

### NMEA 0183 Connection Illustration

Refer to the illustration below when connecting to an external NMEA device via the onboard NMEA 0183 interface.

#### CAMINO-101 NMEA 0183

#### External NMEA device

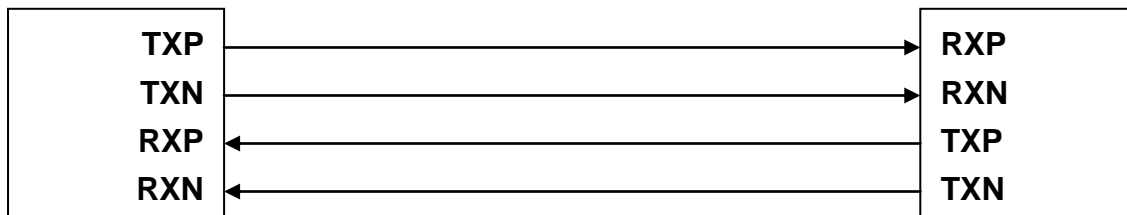

Figure 2-2-3-1 NMEA 0183 connection illustration

- NOTE:**
1. Please make sure the external device is fully NMEA 0183 compliant.
  2. The CAMINO-101 NMEA interface supports the following input sentences: RMC, GGA, GBS, GSA, and HDT.

### 2.2.3.3 RS-232 Connector: Pin Definition and Cable Wiring (CAMINO-101)

The RS-232 connector pins on CAMINO-F

Table 2-2-3-3 RS-232 connector pin definition

NO.	NAME	FUNCTION
1	/	/
2	RX	Receive Data
3	TX	Transmit Data
4	/	/
5	GND	Ground
6	/	/
7	/	/
8	/	/
9	/	/

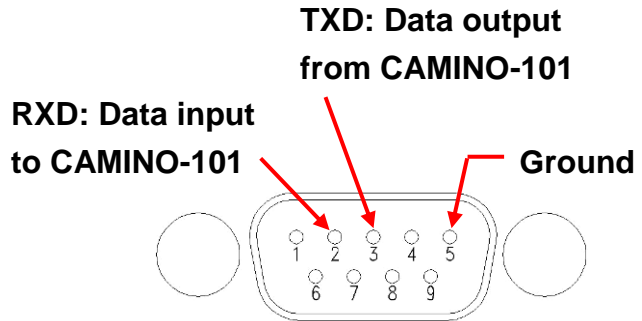

Figure 2-2-3-3 RS-232 Pin definitions, CAMINO-101

### RS-232 Connection Illustration (CAMINO-101)

The RS-232 cable supplied with CAMINO-101 contains 9 different wires. However, only 3 wires are being used. This cable is a cross-over connection, not a straight thru connection. Refer to the following illustration when connecting to an external RS-232 device.

**CAMINO-101 RS-232**  
(DB-9 male)

**PC RS-232**  
(DB-9 female)

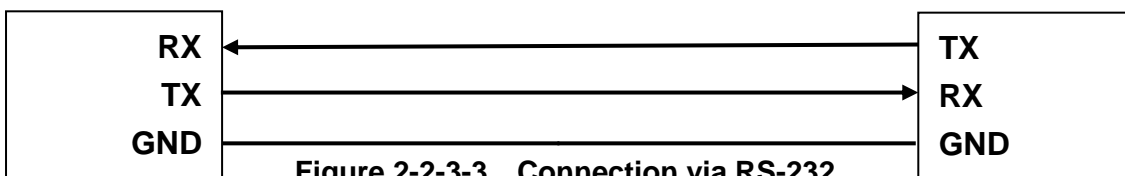

Figure 2-2-3-3 Connection via RS-232

### 2.2.3.4 RS-232 Connector: Pin Definition and Cable Wiring (CAMINO-101A & CAMINO-101W)

CAMINO-101A and CAMINO-101W models RS-232 connector pin assignments on are different than on CAMINO-101 mode

On CAMINO-101A and CAMINO-101W, there are additional pin assignments at the RS-232 connector specifically for connecting to an optional external Tx-off Switch Box. See also Tx-Off Switch Box User Guide.

**Table 2-2-3-4 RS-232 connector pin definitions**

NO.	NAME	FUNCTION
1	/	/
2	RX	Receive Data
3	TX	Transmit Data
4	GND	I/O Ground
5	GND	RS-232 Ground
6	/	Tx-Off
7	/	Tx-Off LED
8	GND	RS-232 Ground
9	GND	I/O Ground

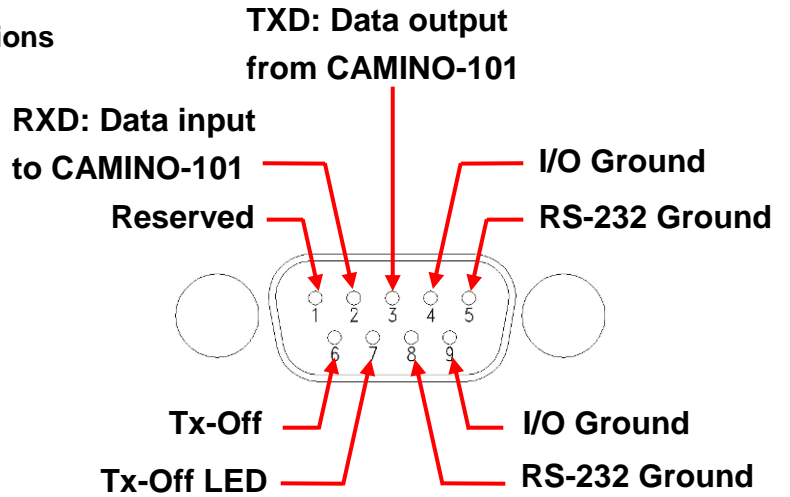

**Figure 2-2-3-4**  
RS-232 Pin definitions, CAMINO-101A / W

**RS-232 Connection Illustration (CAMINO-101A & CAMINO-101W)**

The RS-232 cable supplied with CAMINO-101A & CAMINO-101W consists of 3 wires dedicated for RS-232 connection. (Please note: the 9-wires-RS232-cable used in CAMINO-101 cannot be used for these two CAMINO-101A/W models.) This connection is cross-over and not straight thru. Refer to the following illustration when connecting to an external RS-232 device.

**CAMINO-101A/W RS-232**  
**(DB-9 male)**

**PC RS-232**  
**(DB-9 female)**

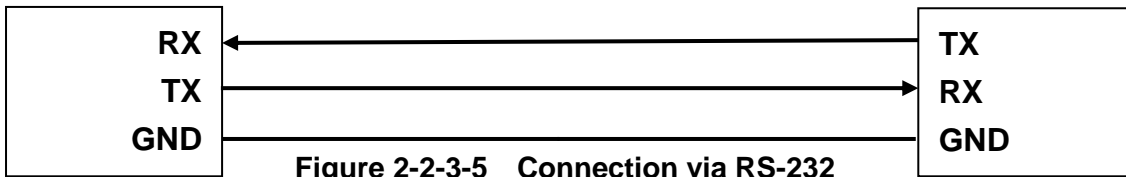
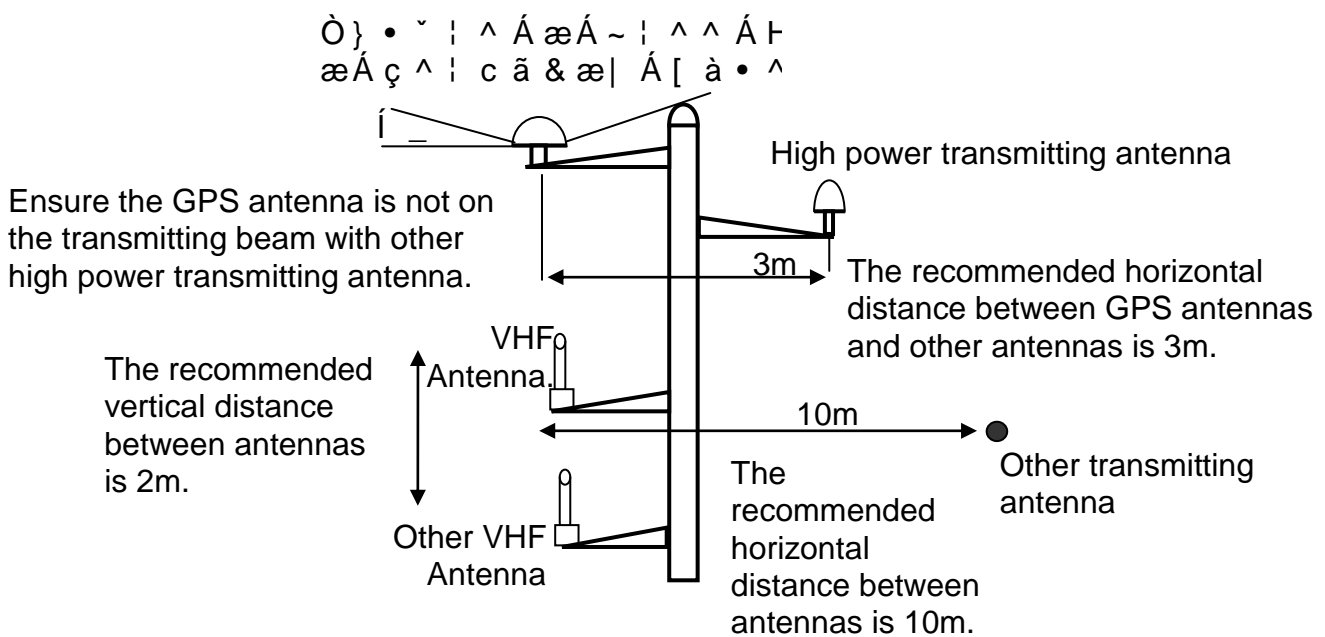

**Figure 2-2-3-5 Connection via RS-232**

## 2.2.4 VHF Antenna Installation

The quality and positioning of the antenna are the most important factors dictating AIS performance. It is recommended that a VHF antenna with omni directional vertical polarization be specifically tuned for AIS operation band. Since the range of VHF signals is largely decided by line of sight distance, the VHF antenna should be placed as high as possible and at least 5 meters away from any constructions made of conductive materials. It is recommended to keep the VHF antenna at least 3 meters away from the CAMINO-101 unit.

To avoid interference, the VHF antenna location should be placed accordingly as on Figure 2-2-4.



**Figure 2-2-4 VHF/GPS Antenna Locations**

We recommend choosing AMEC AIS VHF antenna. To save space, you can also select a VHF/GPS combo antenna provided by AMEC.

### 2.2.5 GPS Antenna Installation

The GPS antenna must be installed where it has a clear view of the sky, so that it may access the horizon freely with 360° degrees, with a vertical observation of 5 to 90 degrees above the horizon as illustrated in Figure 2-2-4.

#### GPS ANTENNA LOCATION

GPS antenna location offsets.

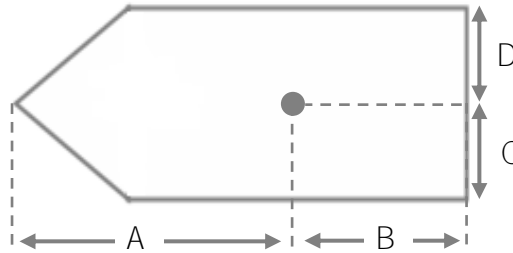

Figure 2-2-5 GPS Antenna location

We recommend choosing AMEC AIS GPS antenna. To save space, you can also select a VHF/GPS combo antenna provided by AMEC.

### 2.2.6 Antenna Cabling

When connecting the cable(s) with the CAMINO-101, take note of the following precautions.

- ① Do not bend the cable(s).
- ② Each coaxial cable should be set up separately and can only be set up in a single cable tube.
- ③ Each coaxial cable should keep a 10m safe distance with the power cable.
- ④ Connecting port of the coaxial cable should be insulated.

## 2.2.7 CAMINO-101 External Connections

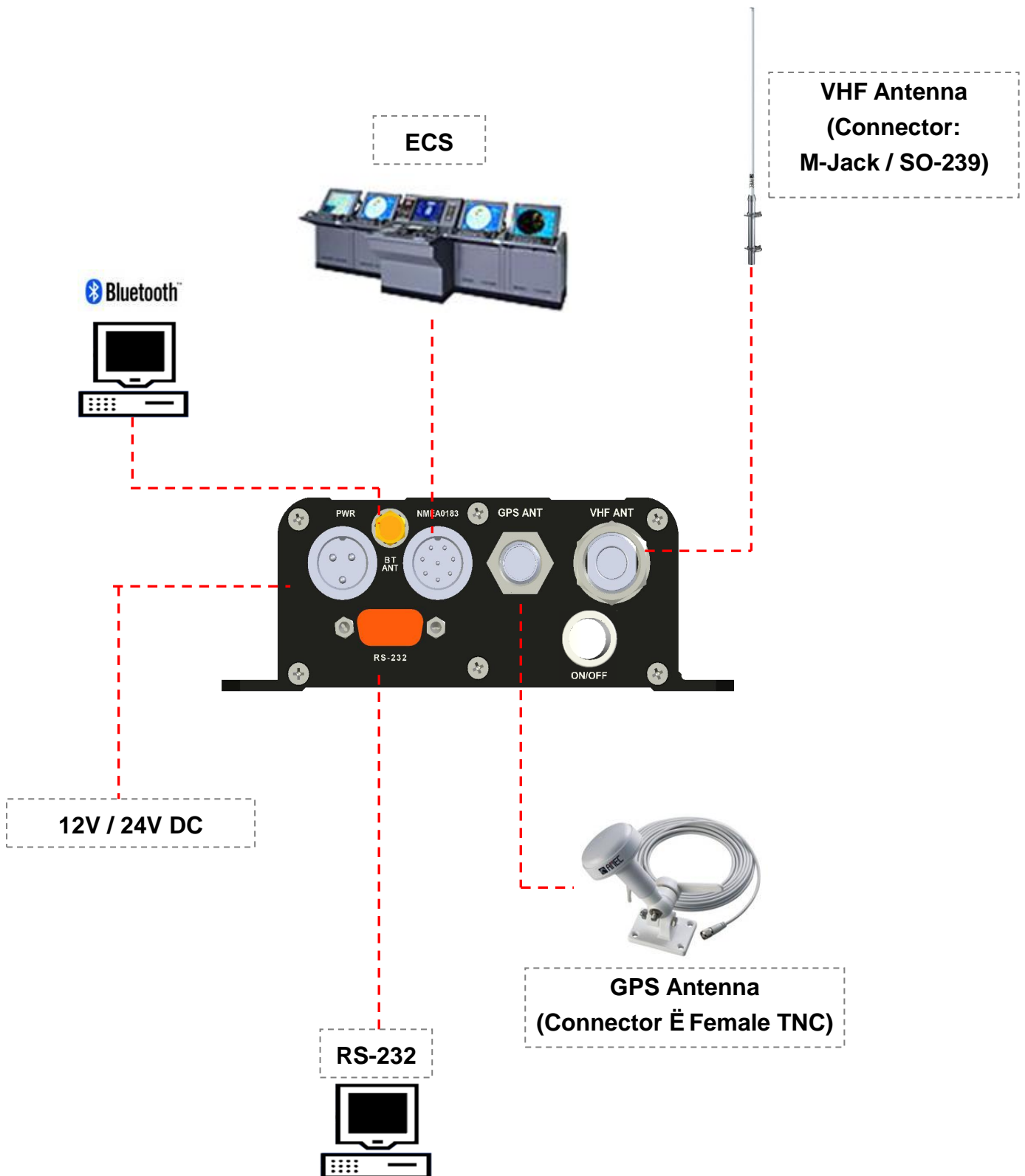



Figure 2-2-7 External configurations

## 2.2.8 AMEC AIS Configuration Software Installation

V @ã • Á ] | [ \* | æ{ Á ^ } æà | ^ • Á ˇ • ^ | • Á c [ Á • ^ c Á ˇ ] Á [ , } Á • œ@ã ] q •  
through computer.

Please find the AMEC AIS Configuration program in the CD supplied and follow the installation instructions below.

**Step 1:** Please open the AMEC AIS Configuration file and click on the setup icon

 AMEC AIS Configuration.exe to start the installation process.

**Step 2:** Please click on  to continue.

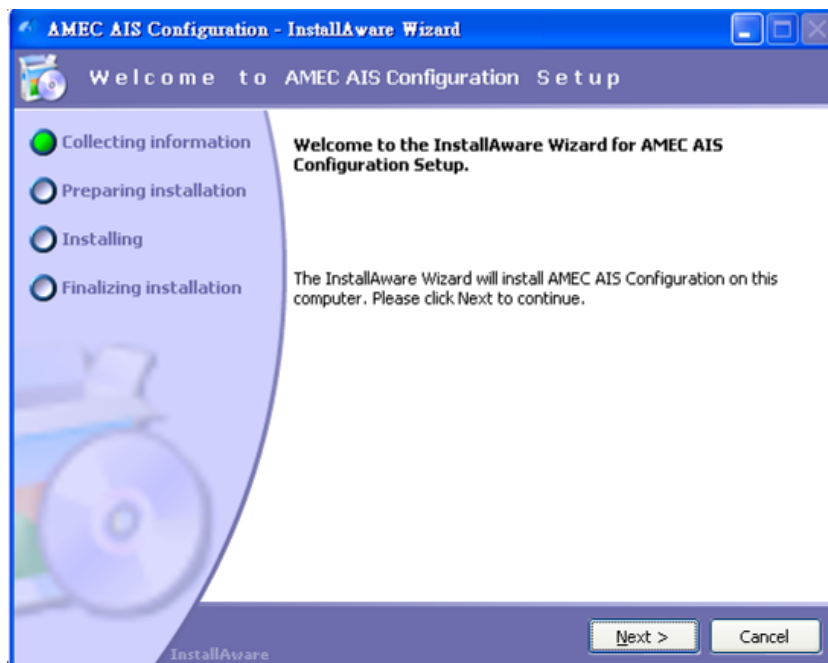
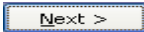
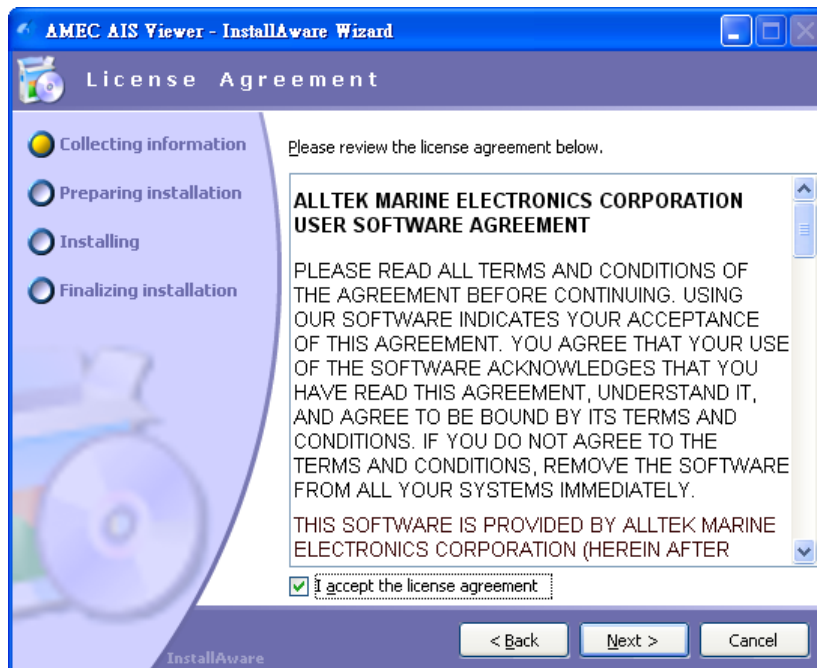

Figure 2-2-8-1 Setup Configuration



**Step 3:** Please read and accept the license agreement before clicking on  to continue.



**Figure 2-2-8-2 Set up Configuration**

**Step 4:** Please fill in the required information and click on  to continue.

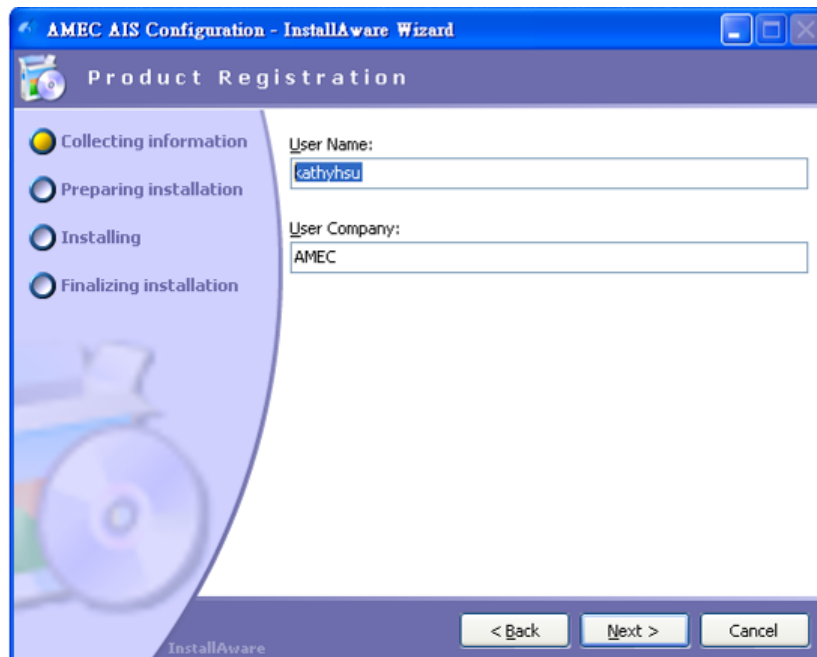

**Figure 2-2-8-3 Set up Configuration**

**Step 5:** Select the destination folder and click on  to continue.

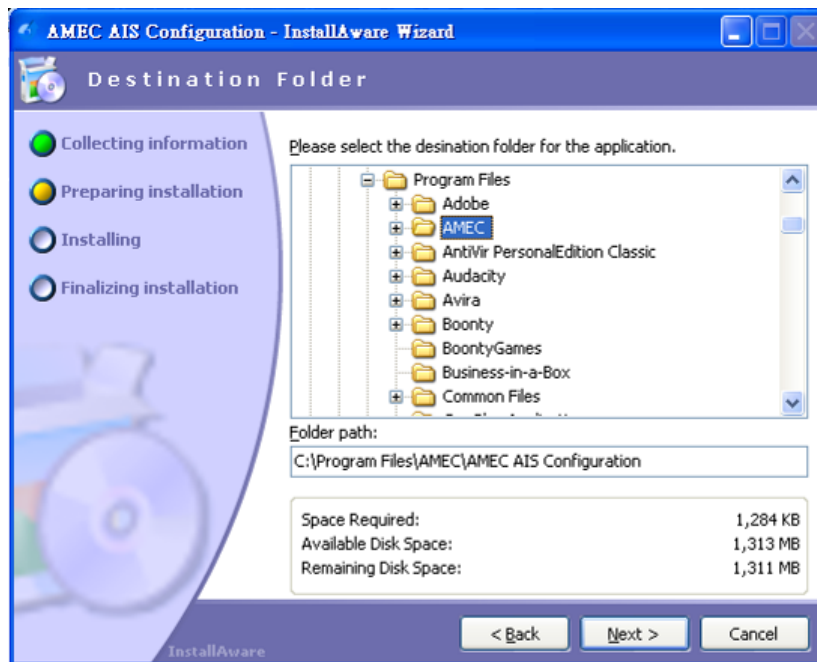

**Figure 2-2-8-4 Set up Configuration**

**Step 6:** Select the Start Menu group for the application and choose users for the program and click on  to continue.

**Figure 2-2-8-5 Set up Configuration**





















































































































